

Technical catalogue

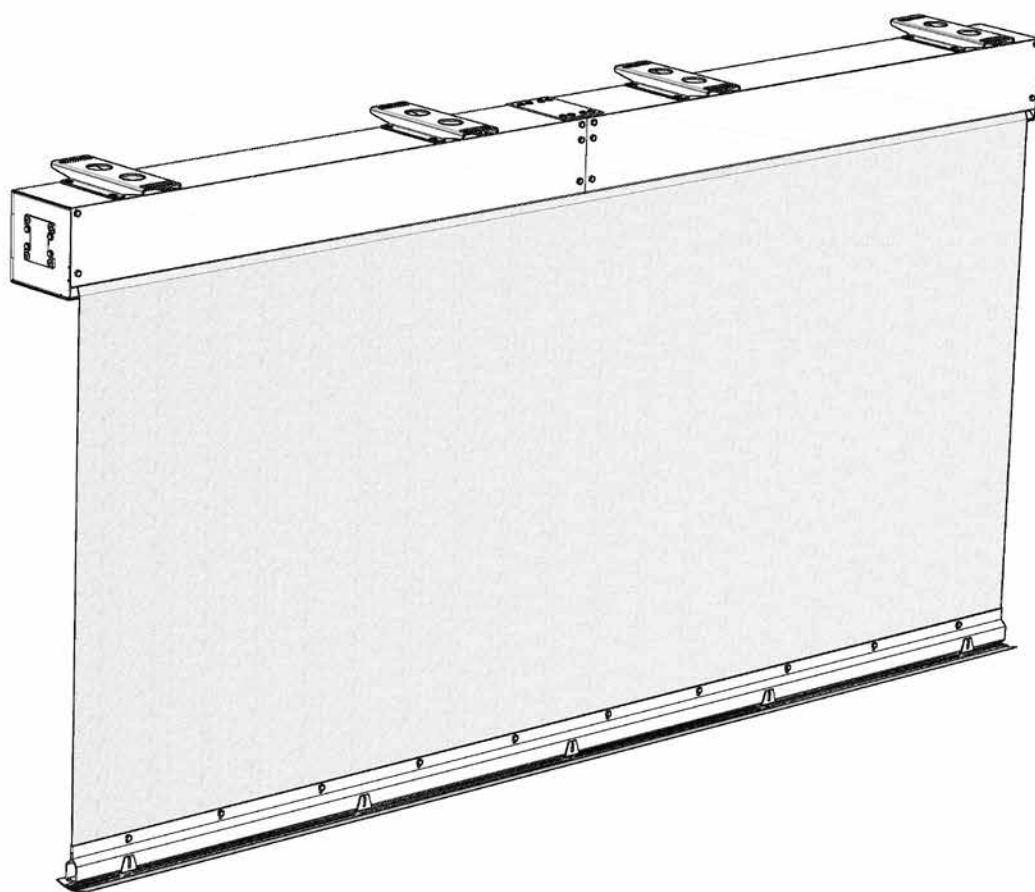

mcr PROSMOKE

SMOKE CURTAINS



Smoke exhaust, heat removal and skylight systems
Technical Catalogue 03/2024

„MERCOR” S.A. with registered office in Gdańsk reserves the right to revise this Technical Catalogue 2024 at any time, without providing a reason. Moreover, any revisions made do not necessitate (at any stage) informing any persons using this Technical Catalogue 2024.

„MERCOR” S.A. also reserves that the contents of this Technical Catalogue 2024 do not constitute a trade offer as defined in art. 66 of Polish Civil Code.

Graphic design and digital typesetting:
„MERCOR” S.A. – Export Department
2024 MERCOR Gdańsk

SMOKE CURTAINS	> 6
1. AUTOMATIC mcr PROSMOKE CURTAINS – FS AND CE TYPE	> 7
1.1 Technical description of standard	> 7
1.2 Single, automatic smoke curtain design	> 7
1.3 Technical drawings – single, automatic smoke curtain	> 8
1.4 Technical drawings – types of mounting brackets (detail a)	> 8
1.5 Technical drawings – casing types	> 9
1.6 Technical drawings – modular automatic smoke curtain in vertical layout	> 10
1.7 Technical drawings – modular automatic smoke curtain in horizontal layout	> 11
1.8 Non-standard options of automatic smoke curtains	> 12
1.9 mcr PROSMOKE FS smoke curtains control	> 13
1.10 Cabling installation diagram – mcr PROSMOKE FS single curtain	> 13
1.11 Cabling diagram – mcr PROSMOKE FS modular curtains	> 14
1.12 mcr PROSMOKE CE curtains control	> 15
1.13 Cabling diagram – mcr PROSMOKE CE single curtain	> 15
1.14 Cabling diagram – mcr PROSMOKE CE modular curtains	> 16
1.15 Installation	> 18
2. AUTOMATIC mcr PROSMOKE ONE CURTAINS – FS AND C TYPE	> 19
2.1 Technical description of standard	> 20
2.2 Single, one case automatic smoke curtain design	> 20
2.3 Casing types	> 20
2.4 Technical drawings – modular automatic smoke curtain in one casing	> 21
2.5 Installation ceiling G-K attached to the curtain	> 22
3. FIXED mcr PROSMOKE CURTAINS – FABRIC, S TYPE	> 23
3.1 Technical description of standard	> 23
3.2 Design of fabric-made fixed smoke curtain	> 23
3.3 Non-standard options	> 23
3.4 Technical drawings	> 24
3.5 Technical details	> 24
3.6 Installation	> 25
4. FIXED mcr PROSMOKE CURTAINS – STEEL, ST TYPE	> 26
4.1 Technical description of standard	> 26
4.2 Design of steel fixed smoke curtain	> 26
4.3 Non-standard options	> 26
4.4 Technical drawings	> 27
4.5 Technical details	> 28
4.6 Installation	> 28

Technical catalogue

2024

Dear Clients,

We are pleased to present to you our technical catalogue for smoke exhaust, heat removal and skylight systems. This publication presents in detail „MERCOR” S.A. products, starting from smoke vents and skylights, through smoke curtains, new generation roof hatches, all the way to the comprehensive review of our control systems. We believe the form in which we present our offer facilitates finding all the necessary information on the individual product series, their components, as well as detailed specifications for the elements of each product offered.

Every merchandise delivered from „MERCOR” S.A. to the Client is meticulously controlled in accordance with the highest quality assurance standards, and undergoes a number of approval tests. We take pride in providing safety through our business.

We invite you to see the full extent of our offer.

„MERCOR” S.A. - Export Department

Electronic copy
of Technical Catalogue available
at www.mercor.com.pl







Smoke curtains

Smoke curtains are one of the most important elements of natural smoke exhaust system. Due to their basic function – separation of smoke zones within a building, they allow to:

- » stop the spreading of smoke within the building,
- » direct smoke flow towards smoke exhaust devices installed in the building.

Depending on the characteristics of the building, natural smoke exhaust systems comprise:

- » fixed smoke curtains (fabric or steel),
- » automatic smoke curtains.

Parameters		FS smoke curtain automatic (gravitational drop)	CE smoke curtain automatic (extended by motor)	S smoke curtain fixed (fabric)	ST smoke curtain fixed (steel)
					
Classification (as per Certificate of Conformity according to EN 12101-1)		Certificate of constancy of performance 1396-CPR-033	Certificate of constancy of performance 1396-CPR-021	Certificate of constancy of performance 1396-CPR-022	Certificate of constancy of performance 1396-CPR-0037
Curtain type (as per standard EN 12101-1)		ASB 1 (*) ASB 2 (*)	ASB 2 (*) ASB 4 (*)	SSB	SSB
Fire resistance class		D30, D60 D180	D30, D60 DH30, DH60	D180 DH60	DH120
Reliability		1000 cycles	1000 cycles	-	-
Response time		max. 60 s	max. 85 s (max. heigh 6.5m)	-	-
Max. material permeability		max. 9.4 m ³ /h·m ²	max. 9.4 m ³ /h·m ²	max. 9.4 m ³ /h·m ²	impermeable
Material		smoke-tight fabric	smoke-tight fabric	smoke-tight fabric	trapezoidal metal sheet
Minimum dimensions	height	0.5 m	0.5 m	0.5 m	0.5 m
	length	2 m	0.8 m	0.8 m	0.5 m
Maximum dimensions	height	6.5 m	6.5 m	8 m	4.5 m
	length	6 m	6 m	50 m	unlimited
Max. number of modules per single control unit mcr 9705		12	5 (**)/10 (***)	-	-
Max. number of modules per single control unit mcr 0204		8	-	-	-
Approximate mass		~ 21 kg/rm	~ 21 kg/rm	~ 10 kg/m ²	~ 7 kg/m ²

(*) **ASB 1** – automatic curtains that do not require an additional source of energy to move into the unfolded position. The curtain falls by gravity at a controlled speed. ASB 1 curtains are designed to operate no lower than 2.5 m above the level of the finished floor. A signal from the curtain's own detectors, a remote trigger signal or cutting off the electric power supply to the curtain motor is treated as a signal that triggers the unfolding (alarm).

ASB 2 – automatic curtains requiring an energy source to move into the unfolded position. The curtain falls thanks to the operation of an electric motor, and the power supply is provided by a 24 V- power supply panel. ASB 2 curtains are designed to operate no lower than 2.5 m above the level of the finished floor. A signal from your own detectors or a remote trigger signal is treated as a signal that triggers the unwinding (alarm).

ASB 3 – automatic curtains that do not require an additional source of energy to move or remain in the unfolded position - without limits on the unfolded height / final level of the lower edge of the curtain in relation to the floor. The maximum unwinding speed of the ASB 3 curtain is lower than that of the ASB 1 curtain.

ASB 4 – automatic curtains requiring an energy source to move or remain in the unfolded position – without limits on the unfolded height / final level of the lower edge of the curtain in relation to the floor. The maximum unwinding speed of the ASB 2 curtain is lower than that of the ASB4 curtains.

(**) with extension module mcr R0424

(***) with extension module mcr R0448

More information about non- standard, automatic smoke curtains: **mcr PROSMOKE ONE type FS/C** on the page 19.

1. | Automatic smoke curtains – FS and CE type

1.1 | Technical description of standard

- » classification as per (EN 12101-1) according to:
 - Certificate of constancy of performance 1396-CPR-0033 (smoke curtains mcr PROSMOKE FS),
 - Certificate of constancy of performance 1396-CPR-0021 (smoke curtains mcr PROSMOKE CE),
- » automatic smoke curtains are responsible for separation of smoke zones within the building, and stop smoke from spreading within passages, on staircases or escalators,
- » automatic smoke curtains are used in buildings where the visual aspect of building plays an important role,
- » the casing of standard dimensions 163 x 163 mm (and 203 x 203 mm, option in case of: FS type when D60 / CE type when D60, DH60), made of galvanized steel sheet, comprises two elements: fixed part and inspection cover, allowing to perform service actions,
- » the casing is a housing for the roller with smoke-tight fabric with weight, and for the curtain drive system,
- » MECU XL motor control unit, installed on casing, allows lowering of curtain for service purposes (FS curtains),
- » brackets made of galvanized steel sheet, allow fixing the curtain to the ceiling or bearing structure using slings in the form of galvanized steel rods with a set of nuts,
- » smoke-tight fabric made of glass fiber, double-coated with polyurethane, sewn horizontally,
- » a bottom ballast is installed in the bottom part of the fabric, for proper unrolling and rolling of curtain, 8 for proper work,
- » the bottom ballast is made of galvanized steel sheet of standard dimensions 31 x 66 mm,
- » bottom ballast made of 3 m long profiles,
- » curtain height range is 0.5 ÷ 6.5 m,
- » maximum length of a single curtain 6.0 m; longer curtains are made in modular configuration,
- » control: electric 24 V- (additional 230 V~ supply for FS curtains).

1.2 | Single, automatic smoke curtain design

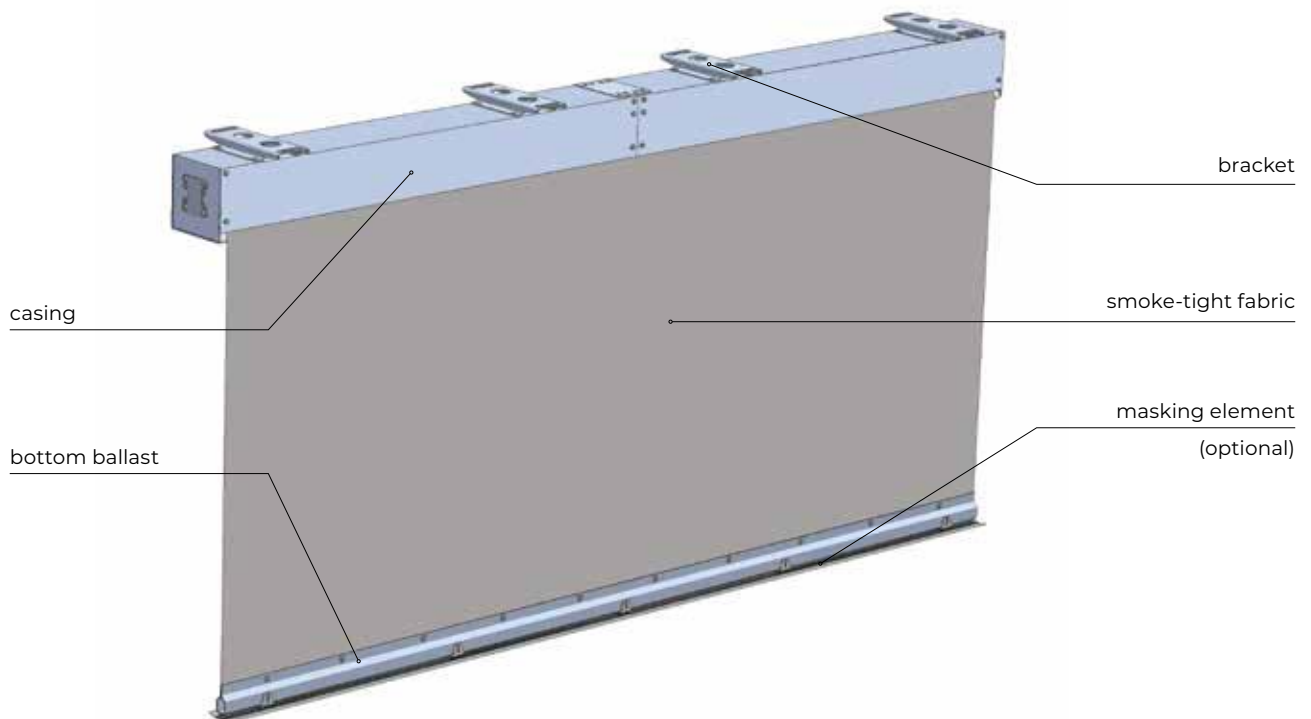

Fig. 1 Design of single, automatic mcr PROSMOKE FS/CE smoke curtain

1.3 | **Technical drawings – single, automatic smoke curtain**

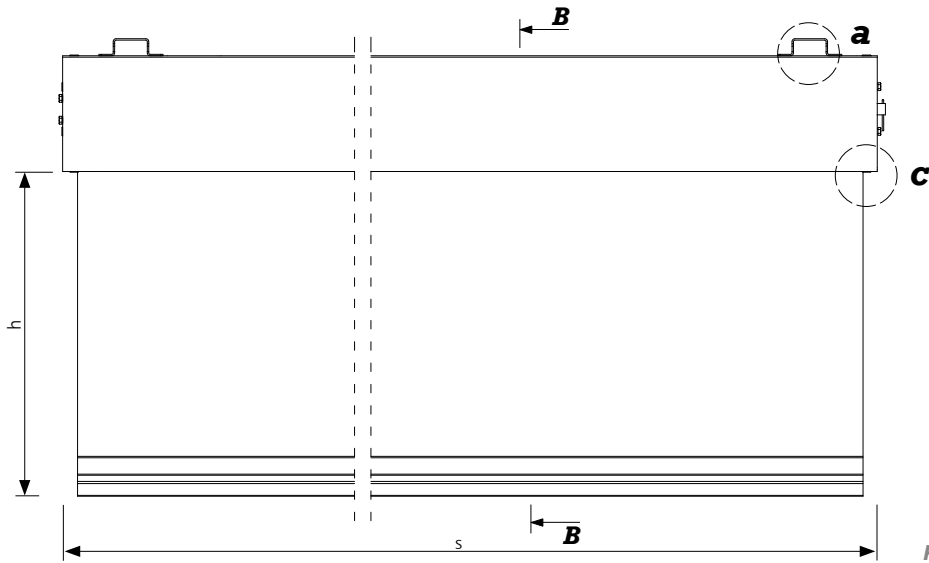

Fig. 2 Single, automatic mcr PROSMOKE FS/CE smoke curtain

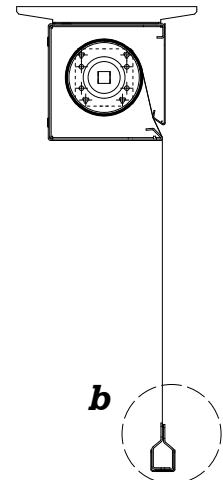
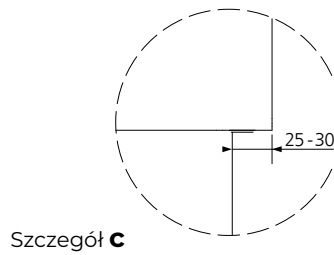
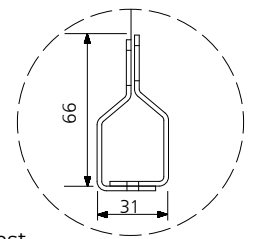

Fig. 3 Section **B-B** of single FS/CE smoke curtain

h – curtain modules height [m]
s – curtain modules length [m]



Szczegół **c**



Detail **b** – Bottom ballast

1.4 | **Technical drawings – types of mounting brackets (detail a)**

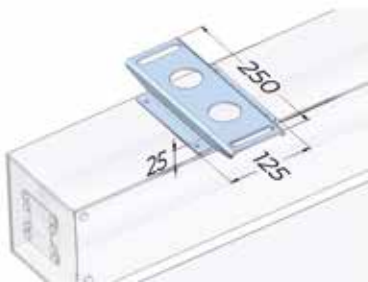

Fig. 4 Wide bracket

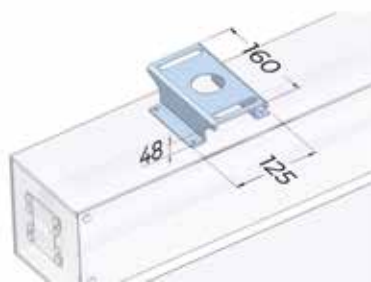

Fig. 5 Narrow bracket

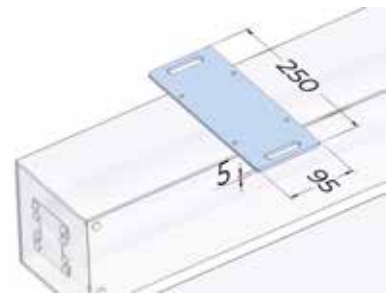
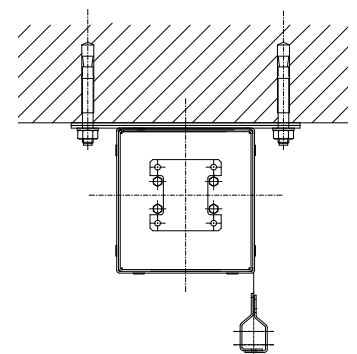
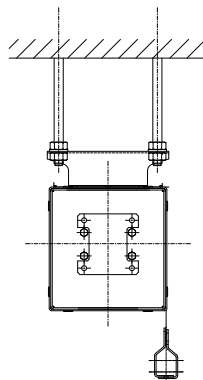
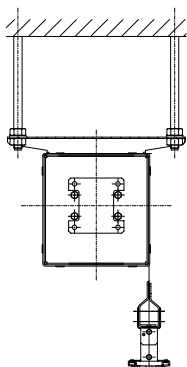

Fig. 6 Flat bracket (*)



(*) not available for mcr PROSMOKE ONE smoke curtain

1.5 | **Technical drawings – casing types**

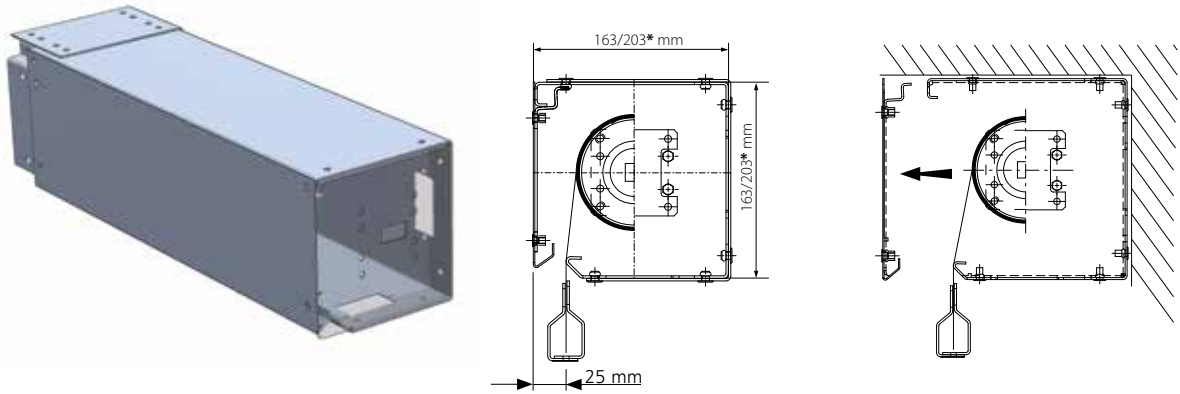

Fig. 7 C casing – curtain rolls down 25 mm from casing edge

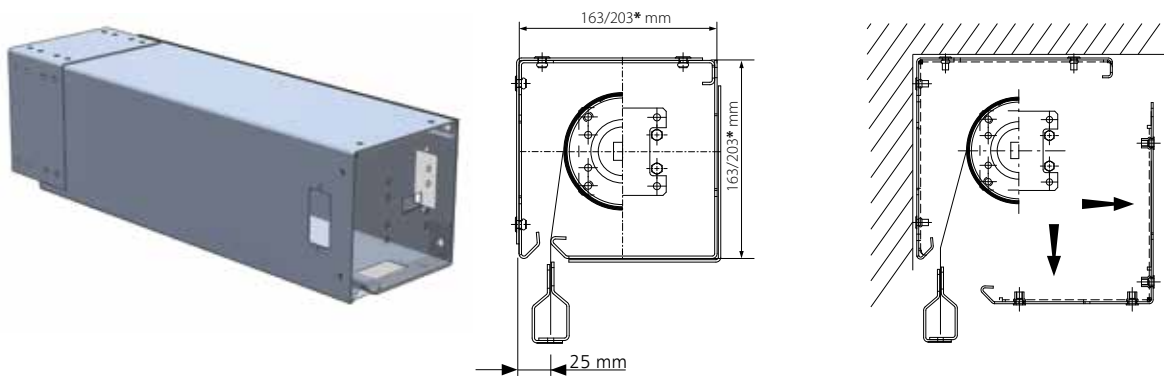

Fig. 8 L casing – curtain rolls down 25 mm from casing edge, allowing to fix curtain directly to the wall

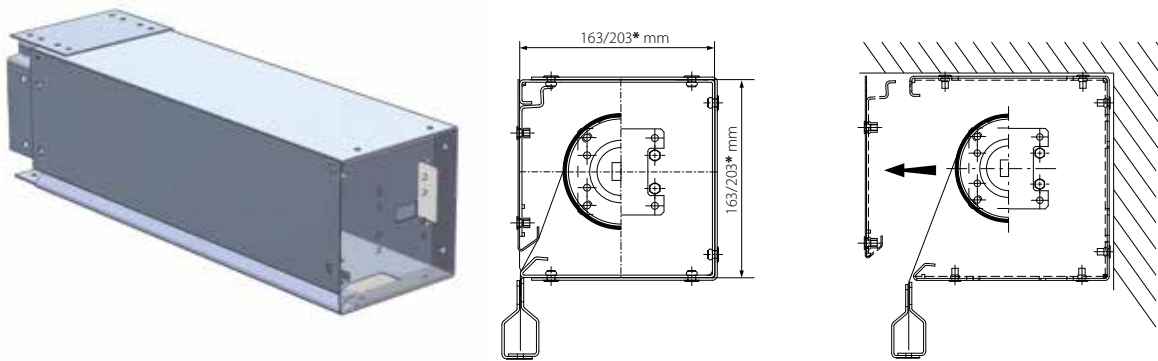

Fig. 9 K(**) casing – curtain rolls down directly by casing edge

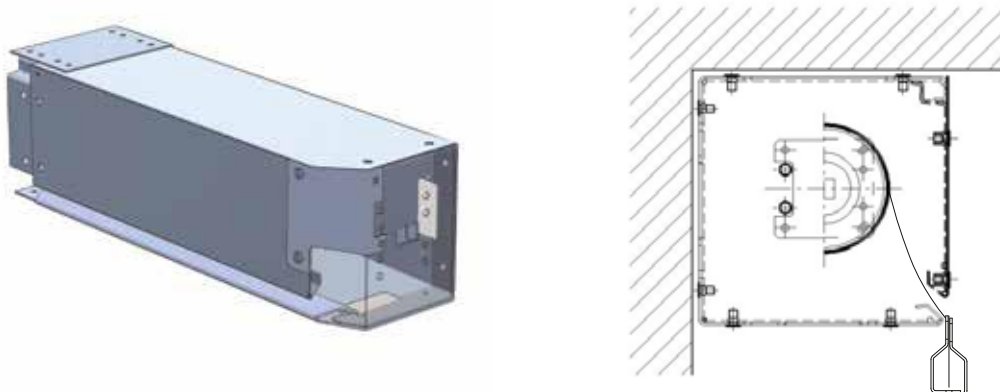

Fig. 10 K-T(**) casing - curtain rolls down directly by casing edge, having angular connections

(*) 203 x 203 mm, casing dimensions in case of: FS type when D60 / CE type when D60, DH60
 (**) K casing also available in K-T version, used for curtains with angular connections

1.6 | **Technical drawings – modular automatic smoke curtain in vertical layout**



Fig. 11 mcr PROSMOKE FS/CE modular smoke curtain in vertical layout



Fig. 12 Top view of mcr PROSMOKE FS/CE modular smoke curtain in vertical layout

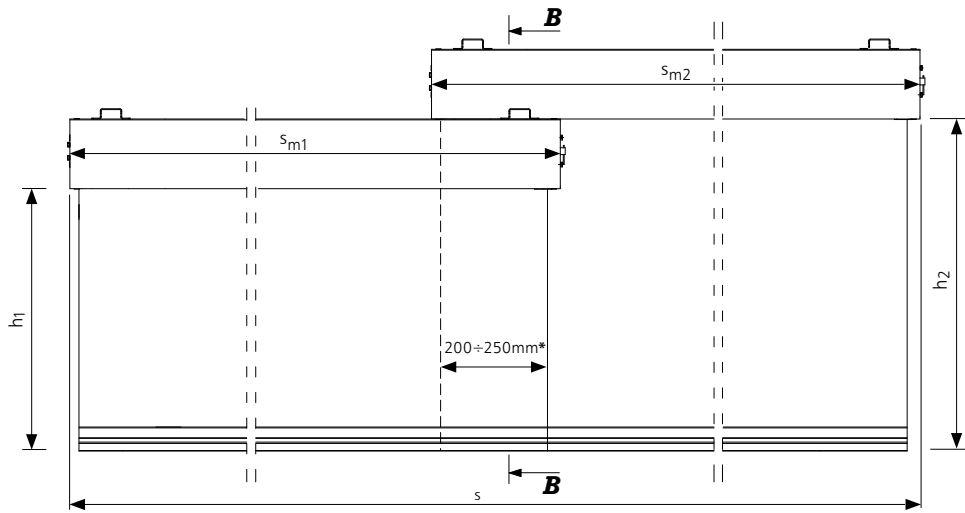

(*) standard material overlap

Fig. 13 mcr PROSMOKE FS/CE modular curtain in vertical layout, with overlap of material

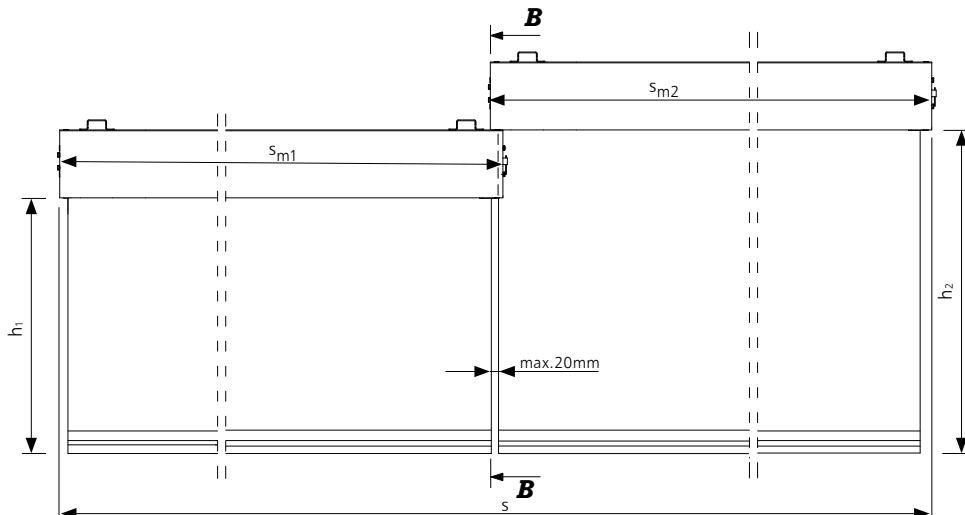

Fig. 15 mcr PROSMOKE FS/CE modular curtain in vertical layout, without overlap of material

h_1, h_2 – curtain modules height [m]
 s_{m1}, s_{m2} – curtain modules length [m]

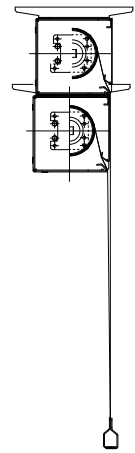

Fig. 14 Section **B-B** of modular smoke curtain in vertical layout.

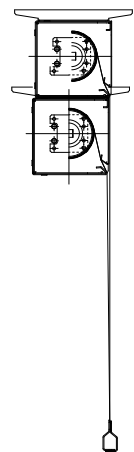

Fig. 16 Section **B-B** of modular smoke curtain in vertical layout.

1.7 | **Technical drawings – modular automatic smoke curtain in horizontal layout**

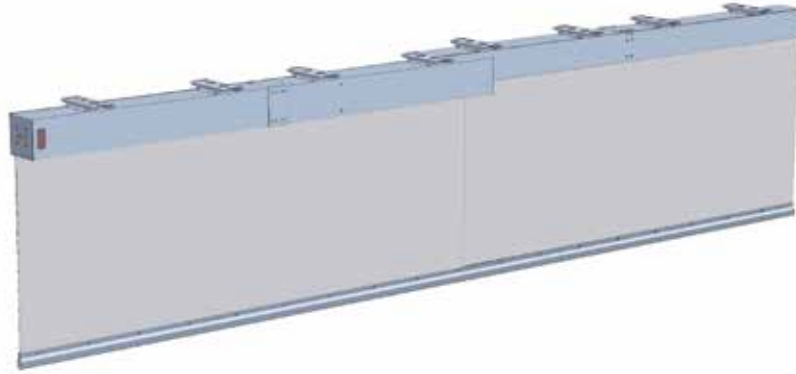

Fig. 17 mcr PROSMOKE FS/CE modular smoke curtain in horizontal layout

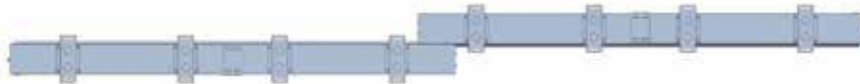
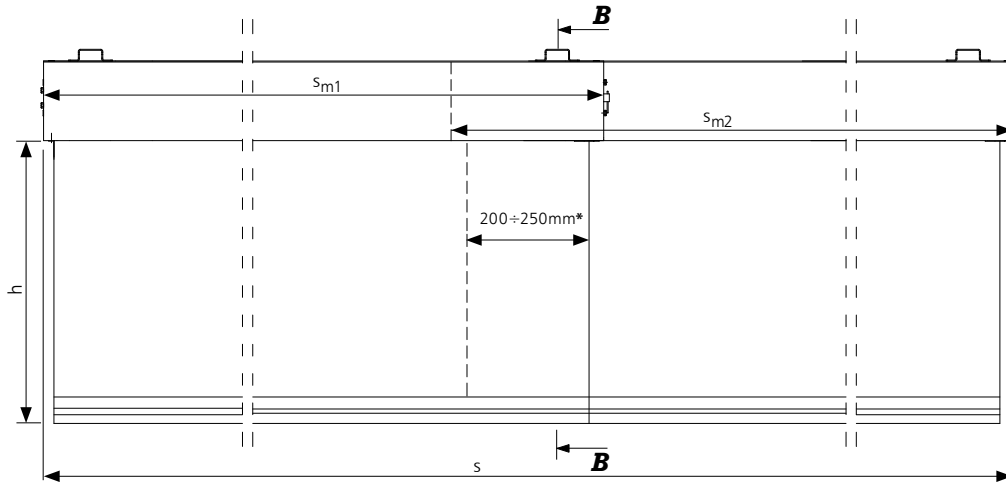

Fig. 18 Top view of mcr PROSMOKE FS/CE modular smoke curtain in horizontal layout



(*) standard material overlap

Fig. 19 mcr PROSMOKE FS/CE modular curtain in horizontal layout, with overlap of material

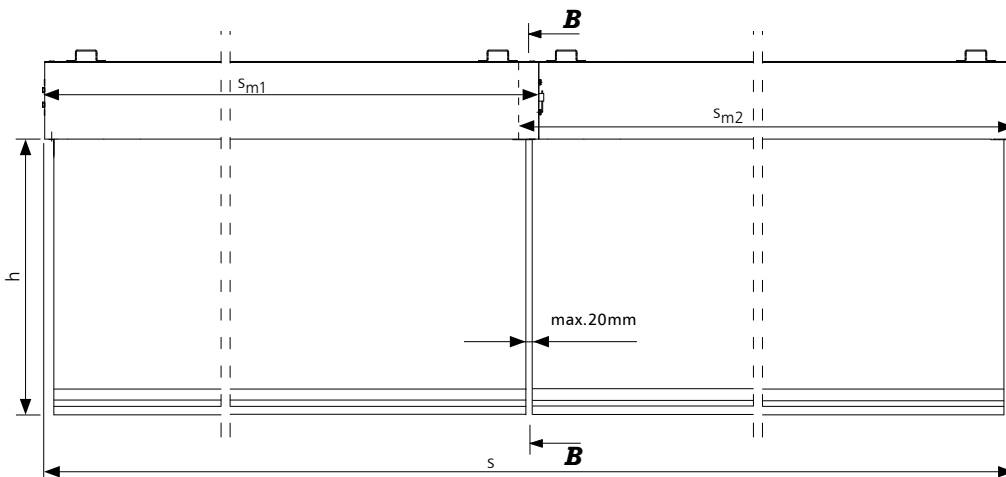

Fig. 21 mcr PROSMOKE FS/CE modular curtain in horizontal layout, without overlap

Fig. 20 Section **B-B** of modular smoke curtain in horizontal layout.

Fig. 22 Section **B-B** of modular smoke curtain in horizontal layout.

h_1, h_2 – curtain modules height [m]
 s_{m1}, s_{m2} – curtain modules length [m]

1.8 | Non-standard options of automatic smoke curtains

- » curtain elements painted to any RAL color (applies to casing, bottom ballast, side guides and masking element),
- » casing dimensions: 203 x 203 mm (external dimensions) for curtains in higher fire resistance class (standard),
- » optional common casing for curtains in case of lack of suspended ceilings.

» Angular connections

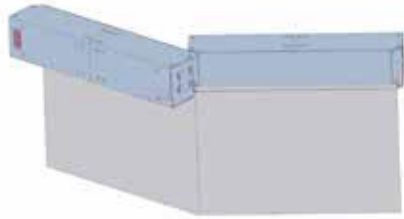

Fig. 23 Curtains connection at obtuse angle

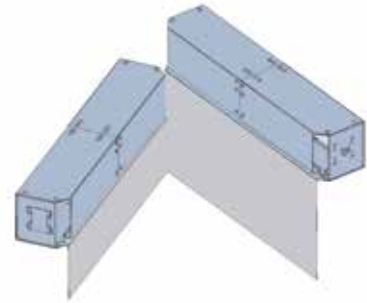

Fig. 24 Curtains connection at acute angle

» Bottom ballast (*)

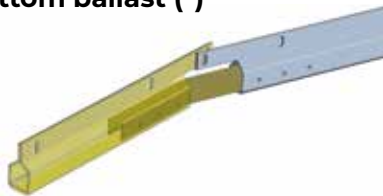

Fig. 25 Bottom ballast for curtains joined at angle

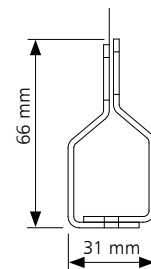

Fig. 26 Section of bottom ballast

» Masking element (cover) for mcr PROSMOKE CE/FS

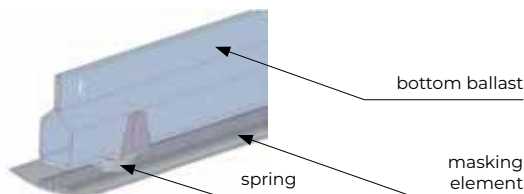

Fig. 27 Masking element with spring and bottom ballast

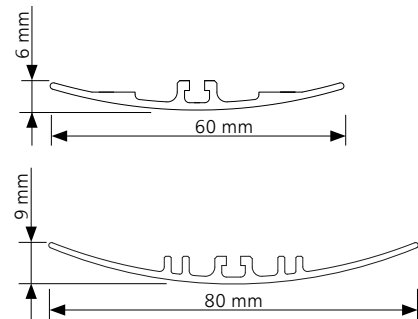

Fig. 28 Section of masking element

» Curtain with side guides

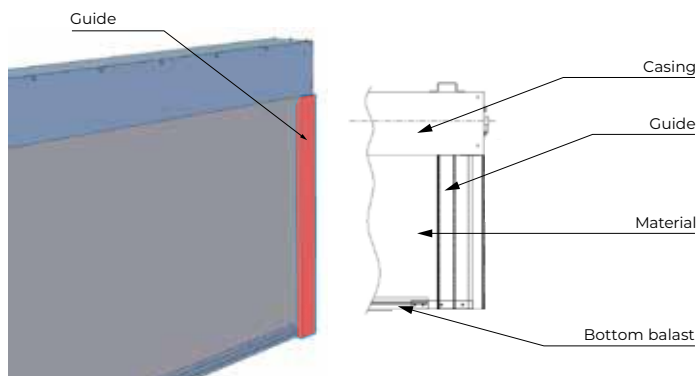

Fig. 29 Side guides installed at both sides of curtain

1.9 | mcr PROSMOKE FS smoke curtains control

mcr PROSMOKE FS automatic smoke curtains remain in stand-by position at continuous 24 V- power supply from mcr 0204 or mcr 9705 control unit. In case of interrupting the supply, which may happen as a result of:

- » alarm signal,
- » failure of 230 V~ power to mcr 0204/mcr 9705 control unit, or discharging of batteries in the control unit,
- » interruption of circuit between mcr 0204/mcr 9705 control unit and MECU XL motor control system,
- » smoke curtain rolls down by gravity force to designed height.

Restoring of the curtain to stand-by position is performed by an actuator (230 V~):

- » after resetting fire alarm signal,
- » after deleting alarm in mcr 0204/mcr 9705 control unit,
- » by pressing reset inside of RPO-1 emergency pushbutton.

mcr PROSMOKE FS drive system comprises motor integrated into the curtain casing.

Motor parameters:

- » torque – 40 Nm
- » power 230 V~ / 265 W (motor)
- » control 24 V-, 0.25 A (brake)
- » work mode – max. 8 minutes
- » installation in a horizontal position
- » working speed 8 rpm.
- » thermal protection of engine by built-in thermo switch
- » powder coated motor casing
- » performance efficiency: 1000 cycles

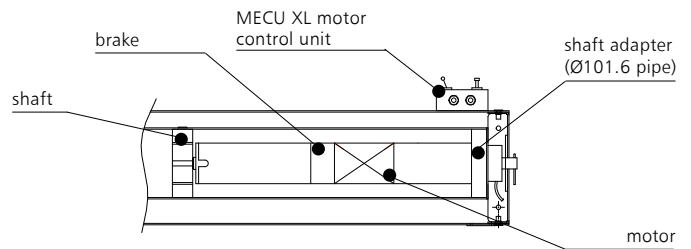

Fig. 30 mcr PROSMOKE FS curtain drive

1.10 | Cabling installation diagram – mcr PROSMOKE FS single curtain

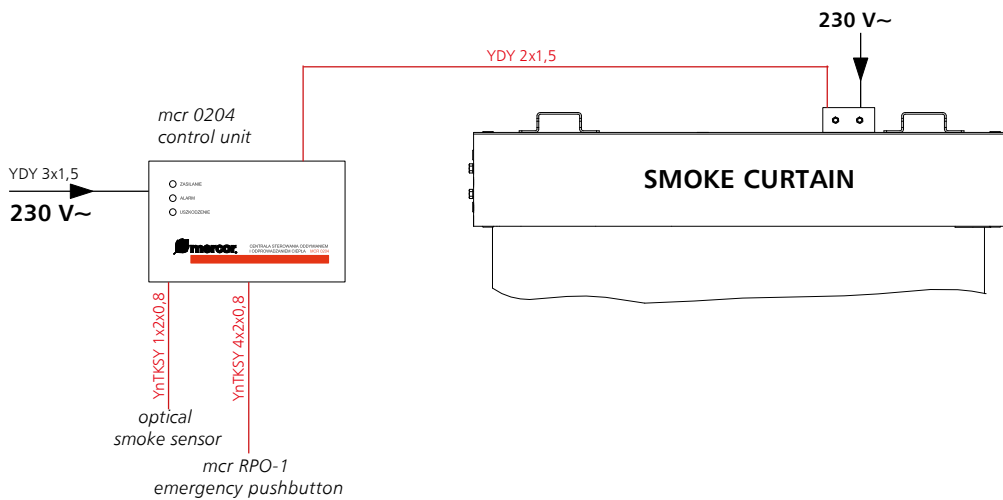

Fig. 31 Cabling diagram of PROSMOKE FS single curtain

1.11 | Cabling diagram – mcr PROSMOKE FS modular curtains

» mcr 0204 control unit – possible connection of up to 8 curtain modules

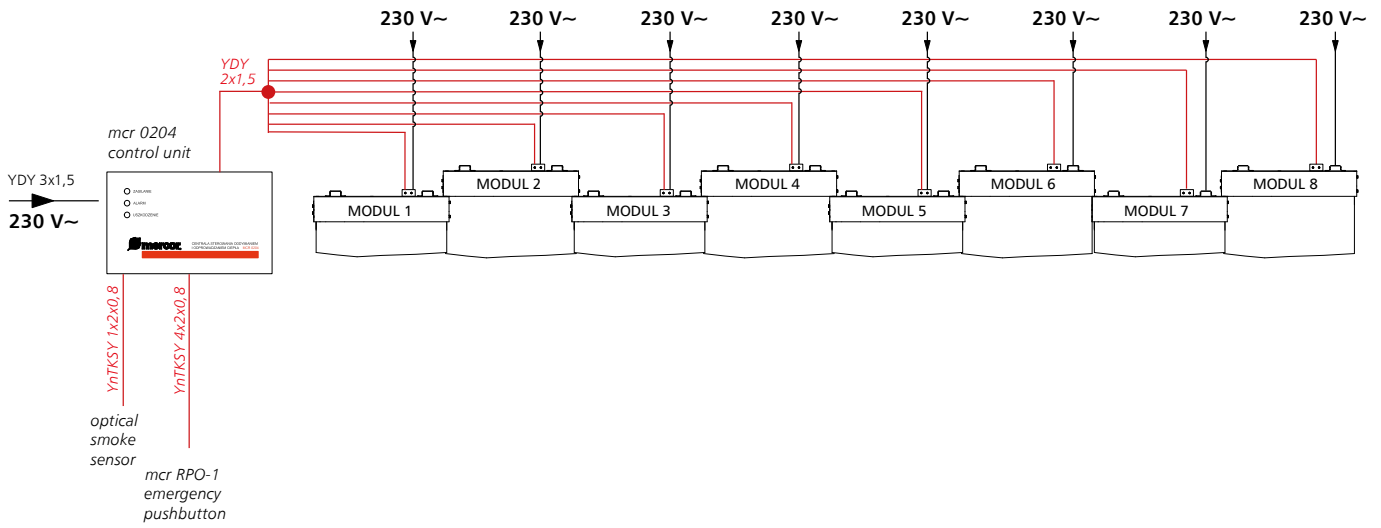

Fig. 32 Connection diagram of maximum number of mcr PROSMOKE FS curtain modules to mcr 0204 control unit

» mcr 9705-5A control unit – possible connection of up to 12 curtain modules

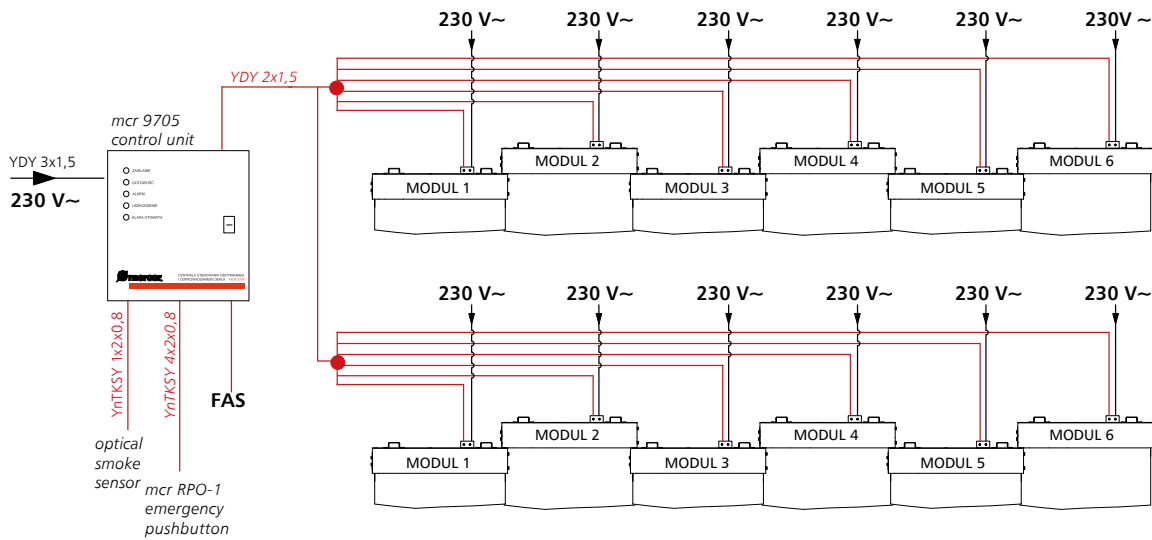

Fig. 33 Connection diagram of maximum number of mcr PROSMOKE FS curtain modules to mcr 9705 control unit

TIME OF HOLDING THE CURTAIN IN STAND-BY POSITION BY mcr CONTROL UNIT AT BASIC POWER FAILURE			
mcr 9705 control unit	1 curtain – up to 20 h	2 curtains – 10 h	3 curtains – 6.5 h etc.
mcr 0204 control unit	1 curtain – up to 12 h	2 curtains – 6 h	3 curtains – 4 h etc.

1.12 | mcr PROSMOKE CE curtains control

In case of fire, mcr PROSMOKE CE automatic smoke curtains roll down:

- » automatically, after signal from fire signaling system,
- » automatically, through the fusing of optical smoke sensors (or thermal sensors) as a result of increase in smoking (temperature),
- » manually, by pressing reset inside of RPO-1 emergency pushbutton.

Alarm signal is given to mcr 9705 control unit. The signal is then transmitted to the curtain actuator, which rolls it down to an appropriate, designed height.

Restoring of the curtain to stand-by position is performed by an actuator:

- » after resetting fire alarm signal,
- » after deleting alarm in mcr 9705 control unit,
- » by pressing RPO-1 emergency pushbutton.

mcr PROSMOKE CE curtain drive system comprises motor, integrated in the curtain casing.

Motor parameters:

- » torque – 60 Nm
- » power: 24 V- (max. 6.3 A)
- » work mode – max. 4 minutes
- » working speed 8 rpm.
- » electromagnetic brake in closed circuit
- » performance efficiency: 1000 cycles

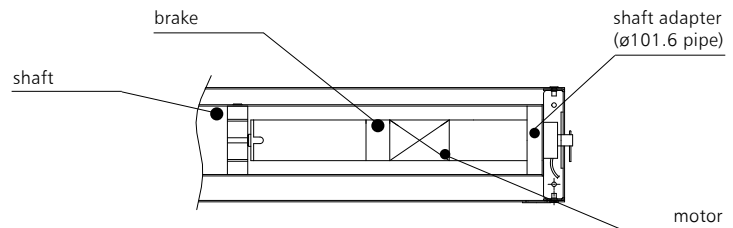

Fig. 34 Cabling diagram of PROSMOKE CE single curtain

1.13 | Cabling diagram – mcr PROSMOKE CE single curtain

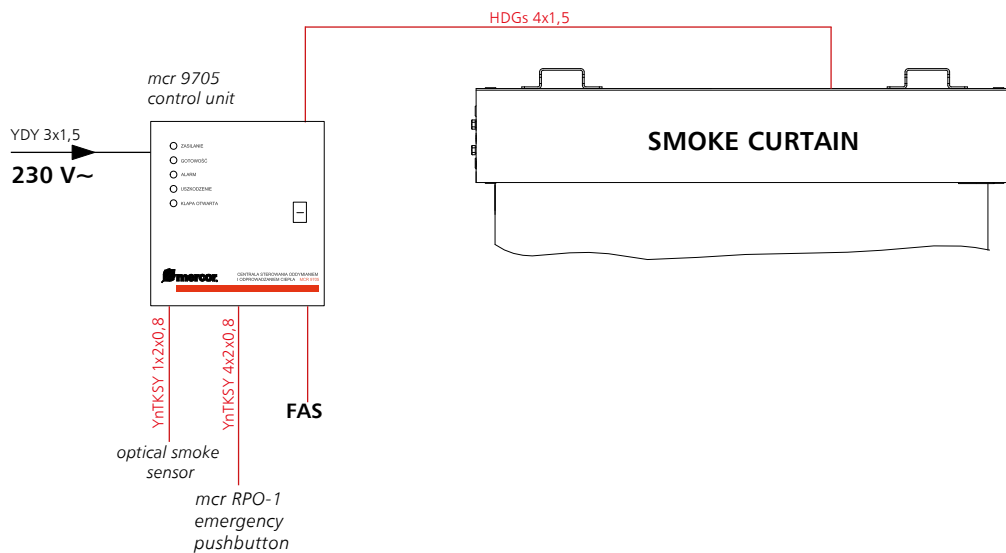

FIG. 35 PROSMOKE CE curtains drive

1.14 | **Cabling diagram – mcr PROSMOKE CE modular curtains**

» **mcr 9705 control unit – possible connection of up to 2 curtain modules**

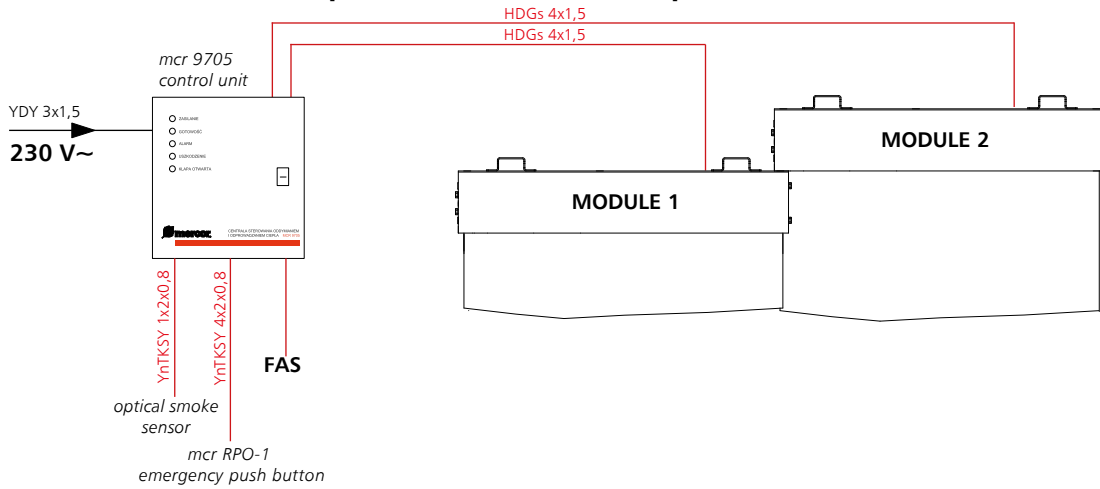

Fig. 36 Connection diagram of maximum number of mcr PROSMOKE CE curtain modules to mcr 9705 control unit

» **mcr 9705 control unit with mcr R0424 extension module – possible connection of up to 4(*) curtain modules**

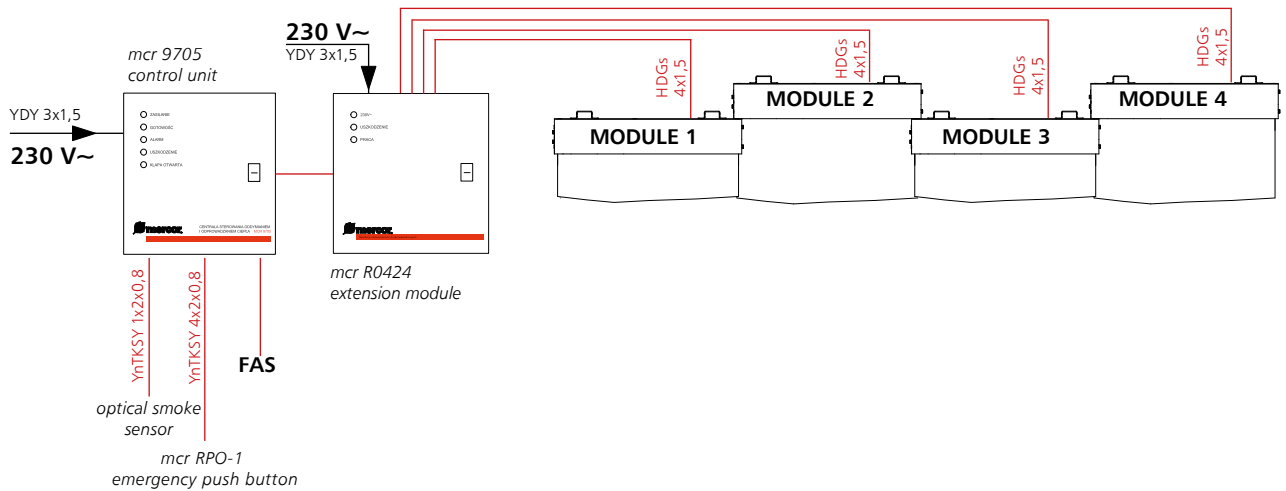

Fig. 37 Connection diagram of maximum number of mcr PROSMOKE CE curtain modules to mcr 9705 control unit with mcr R0424 extension module

» **mcr 9705 control unit with mcr R0424 extension module – possible connection of up to 5(**) curtain modules**

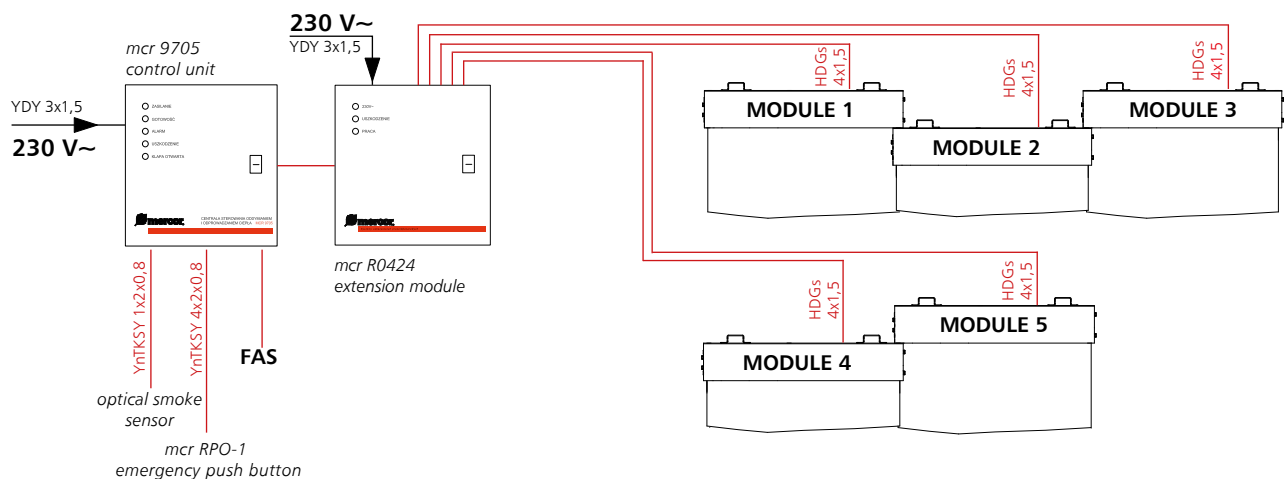

Fig. 38 Connection diagram of maximum number of mcr PROSMOKE CE curtain modules to mcr 9705 control unit with mcr R0424 extension module

(*) Maximum curtain module length 4 ÷ 6 m

(**) Maximum module length 3.99 m

» **mcr 9705 control unit with mcr R0448 extension module – possible connection of up to 8 (*) curtain modules**

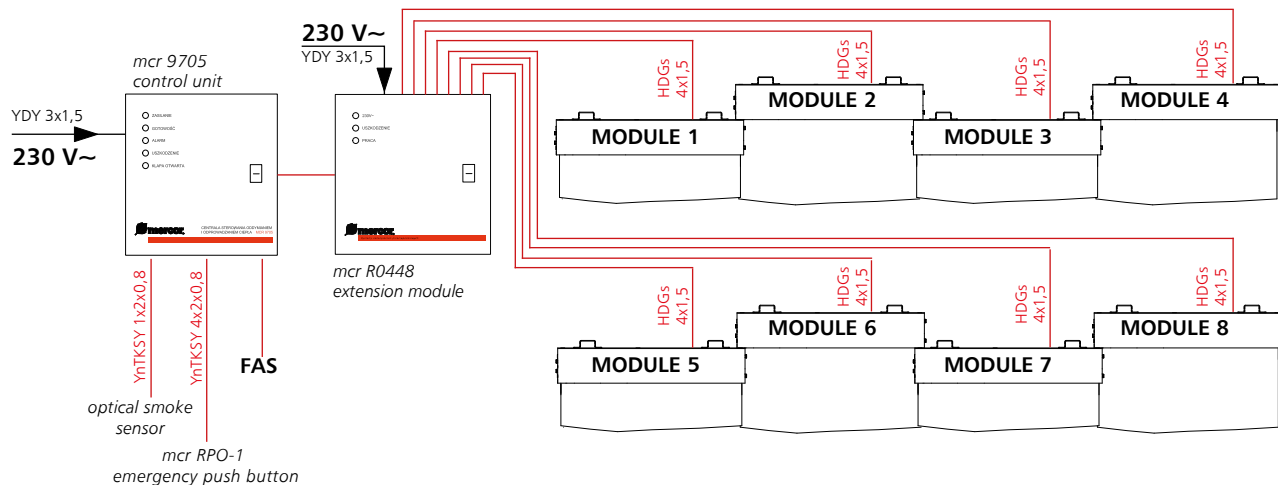

Fig. 39 Connection diagram of maximum number of mcr PROSMOKE CE curtain modules to mcr 9705 control unit with mcr R0448 extension module

» **mcr 9705 control unit with mcr R0448 extension module – possible connection of up to 10 (**) curtain modules**

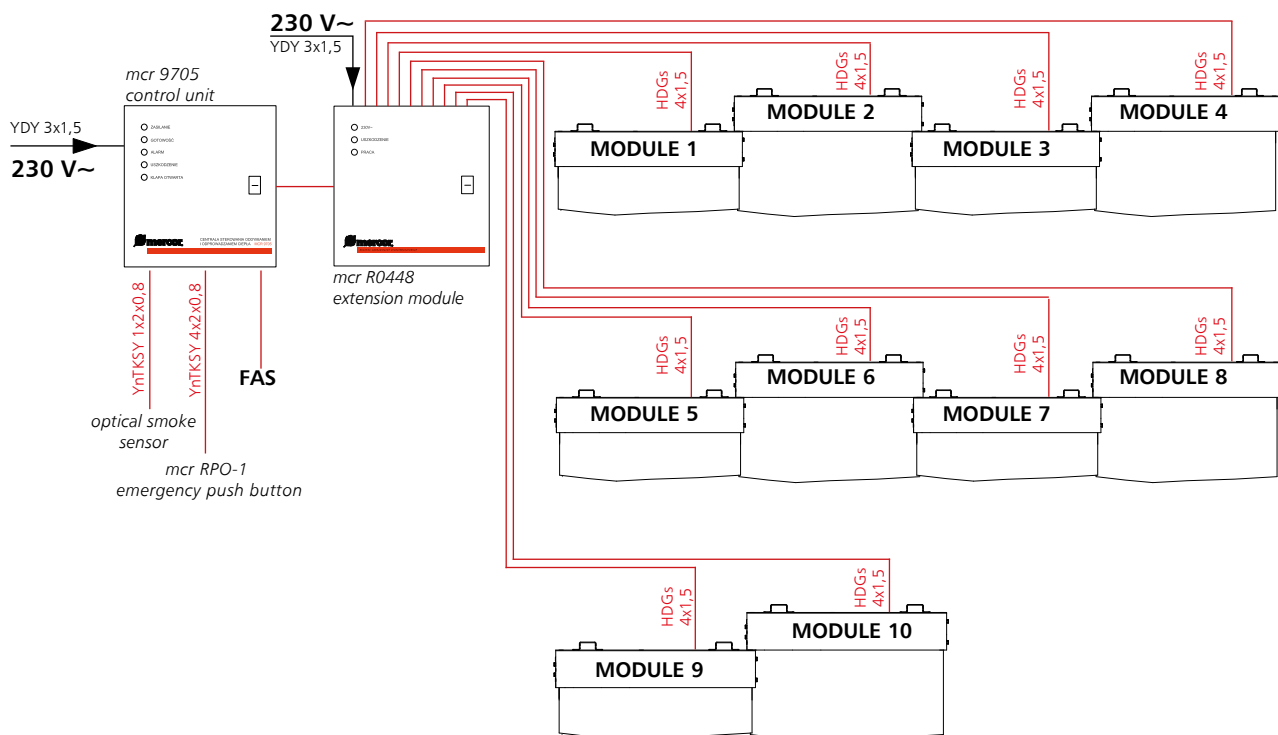

Fig. 40 Connection diagram of maximum number of mcr PROSMOKE CE curtain modules to mcr 9705 control unit with mcr R0448 extension module

(*) Maximum curtain module length 4 ÷ 6 m
 (**) Maximum module length 3.99 m

The time of keeping the curtain in stand-by position by mcr 9705 control unit at basic power failure is 72 hours.

1.15 | Installation

- » smoke curtains must be installed in accordance with the construction design, while maintaining all designed gap dimensions, as specified in EN-EN 12101-1, with maximum values as follows:
 - 20 mm for curtains of height up to 2 m,
 - 40 mm for curtains of height 2÷6 m,
 - 60 mm for curtains of height above 6 m,
- » when designing the load bearing element, bottom ballast of about 250÷300 N/mb must be taken into consideration; different types of handles and curtain casings must be used depending on curtain height and installation place;
- » the use of masking element allows to completely hide the curtain in the under-ceiling space when installing modular curtains; observe the order of installation of individual modules as follows: end module, middle modules, far-end module
- » when installing modular curtains it is necessary keep the required overlapping dimensions of smoke-tight fabric of individual modules.

Seal the gaps around the curtain casing in accordance with the building project. Alternatively, guidelines from CEN/TR 12101-4 or relevant national regulations can be used.

» Automatic smoke curtain order of installation:

1. casing with the use of handles with steel rods to the building's bearing structure,
2. bottom ballast,
3. masking element.

» Installing automatic curtains to ceiling

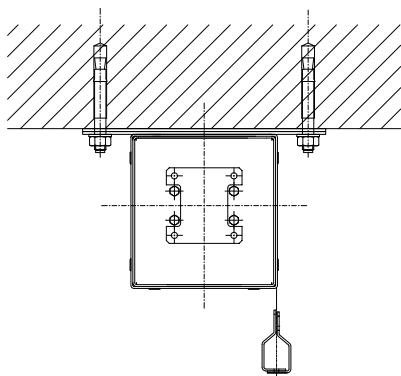

Fig. 41 Fixing curtain directly to ceiling using flat bracket

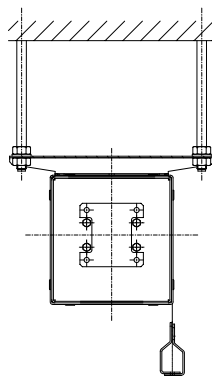

Fig. 42 Fixing curtain directly to ceiling using wide bracket

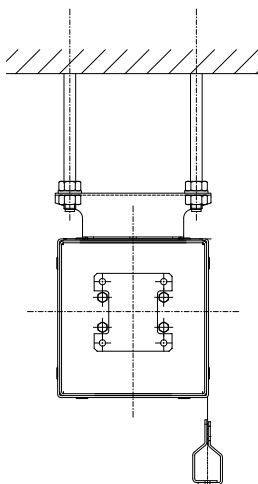

Fig. 43 Fixing curtain to rods using narrow bracket

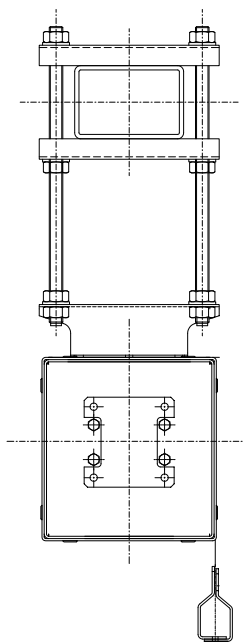

Fig. 44 Fixing curtain to section using narrow bracket and clamp

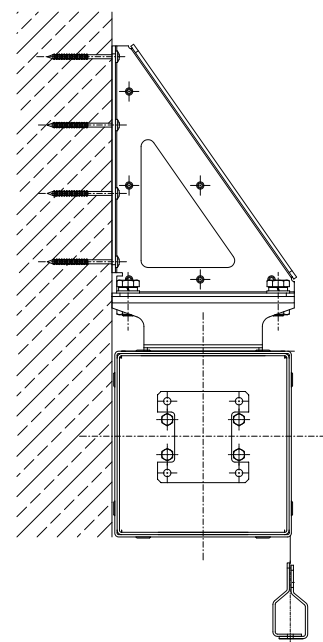

Fig. 45 Fixing curtain to wall using narrow bracket

2.] Automatic smoke curtains – mcr PROSMOKE ONE FS and C type

The module of element, Active smoke barrier mcr PROSMOKE ONE FS and mcr PROSMOKE ONE C, consists of a curtain casing, one tube or two and more tubes one over the other or one next to other, an electric drive and a fabric with bottom bar (optionally with aluminium covering profile).

Comparing to regular automatic smoke curtain mcr PROSMOKE , mcr PROSMOKE ONE has:

- » one common casing for all shafts,
 - » final assembly carried out at site (no at production),
 - » similar parameters as mcr PROSMOKE CE/FS,
 - » material unification: shaft (pipe 101,6), fabrics, sewing, drive and control.
- The load can be changed in comparison to the currently used (have been).

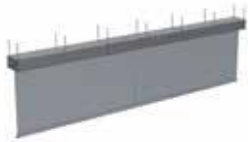
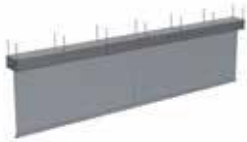
Parameters		ONE FS smoke curtain automatic – gravitational drop	ONE C smoke curtain automatic – extended by motor
			
Classification (as per Certificate of Conformity according to EN 12101-1)		Certificate of constancy of performance 1396-CPR-0132,	Certificate of constancy of performance 1396-CPR-0133,
Curtain type (as per standard EN 12101-1)		ASB1 / ASB3	ASB2 / ASB4
Fire resistance class		D30 / D180 / DH30 FIRES-JR0-142-22	D30 / DH30 FIRES-JR0-142-22
Reliability		1000 cycles	1000 cycles
Max. barrier permeability tested at ambient temperature		9,4 m ³ /h·m ²	
Material		smoke-tight fabric	
Max shafts No.		12	10
Minimum dimensions	height	0.5 m	
	length	2 m	0,8 m
Maximum dimensions	height	6.5 m	
	length	5.4 m	
Masking		60 mm or 80 mm (only for curtain's casing mounted above the suspended ceiling)	
Angle connections		NO	
Max power consumption	24 V-	0.25 A (brake)	4 A (motor)
	230 V~	270 W (motor)	-
Control panel		mcr 9705-5A / mcr 0204	mcr 9705-5A/-8A
Extension module (optional)		-	mcr R0424/-48 -Kx

2.1 | Technical description of standard

- » automatic smoke curtains FS and C are responsible for separation of smoke zones within the building, and stop smoke from spreading within passages, on staircases or escalators,
- » automatic smoke curtains are used in buildings where the visual aspect of building plays an important role,
- » fire resistance parameters:
 - **FS type:** D30 / D180 / DH30,
 - **C type:** D30 / DH30,
- » vast range of curtain mounting to ceiling lintel or object steel construction,
- » automatic curtain as one folded or modular device can be connected under an angle or contain evacuation entrance,
- » painting steel components with chosen RAL palette colour,
- » classification (as per EN 12101) according to:
 - Certificate of constancy of performance 1396-CPR-0132 (mcr PROSMOKE ONE FS curtains),
 - Certificate of constancy of performance 1396-CPR-0133 (mcr PROSMOKE ONE C curtains).

2.2 | Single, one case automatic smoke curtain design mcr PROSMOKE ONE

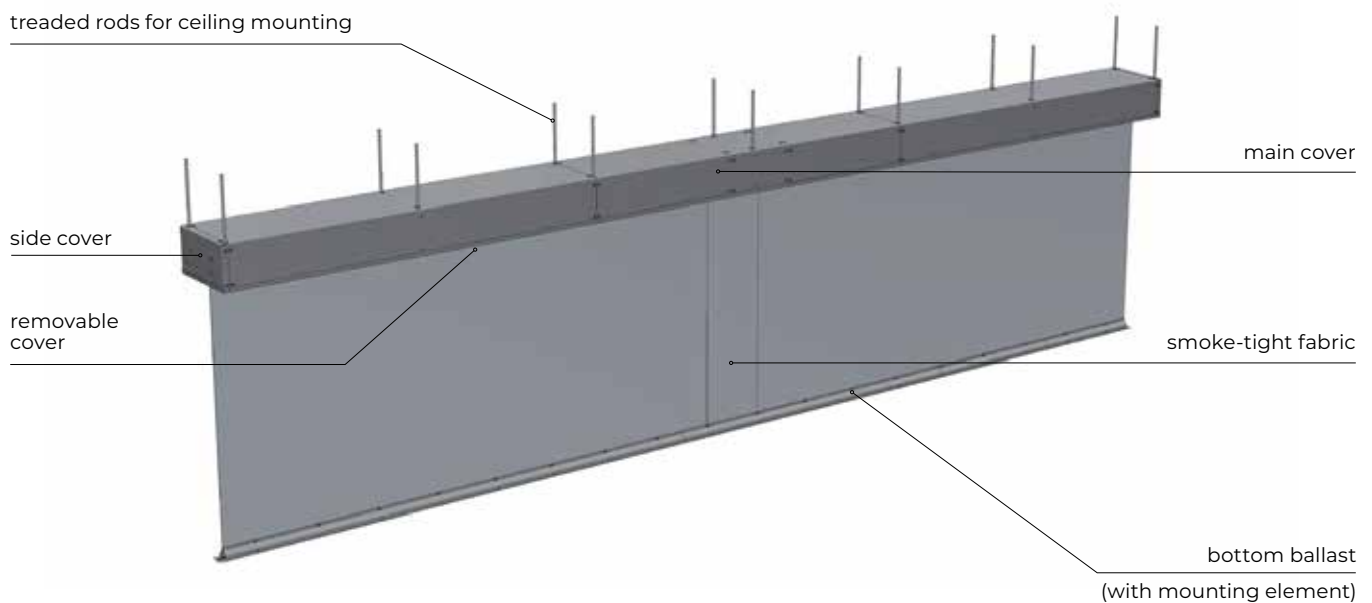

Fig. 46 mcr PROSMOKE ONE modular automatic smoke curtain in one casing



Fig. 47 Top view of mcr PROSMOKE ONE modular automatic smoke curtain in one casing

2.3 | Casing types:

- » **Casing Type S** – shafts arranged in the axis,
- » **Casing Type H** – shafts placed on one level,
- » **Casing Type V** – shafts placed vertically.

2.4 | **Technical drawings – modular automatic smoke curtain in one casing(**)**

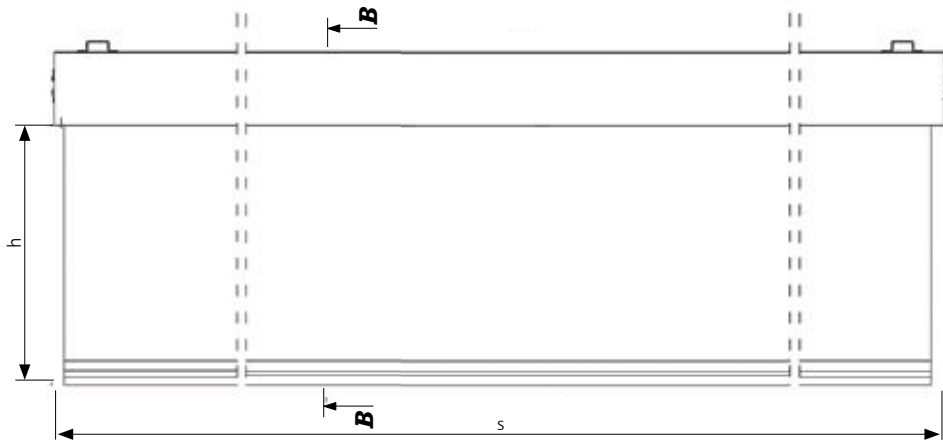

Fig. 48 *mcr PROSMOKE ONE modular automatic smoke curtain in one casing S*

(**) WARNING! Max. length of the curtain mcr PROSMOKE ONE with S type casing is 5.4 m

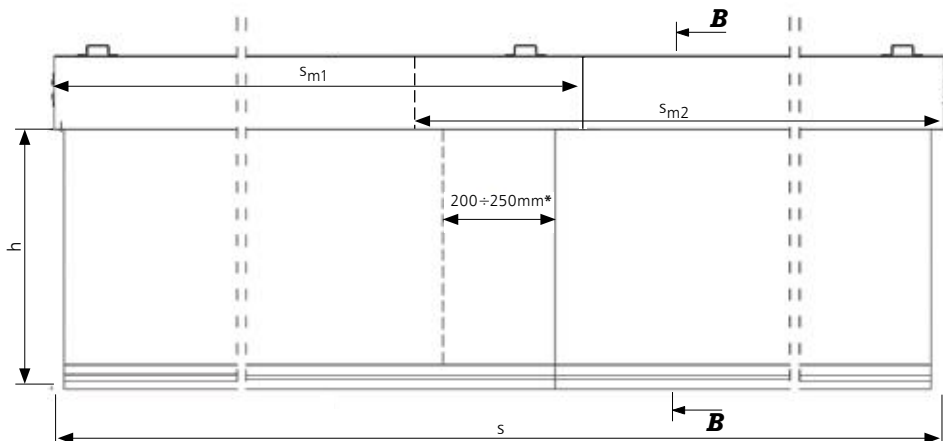

Fig. 50 *mcr PROSMOKE ONE modular automatic smoke curtain in one casing H*

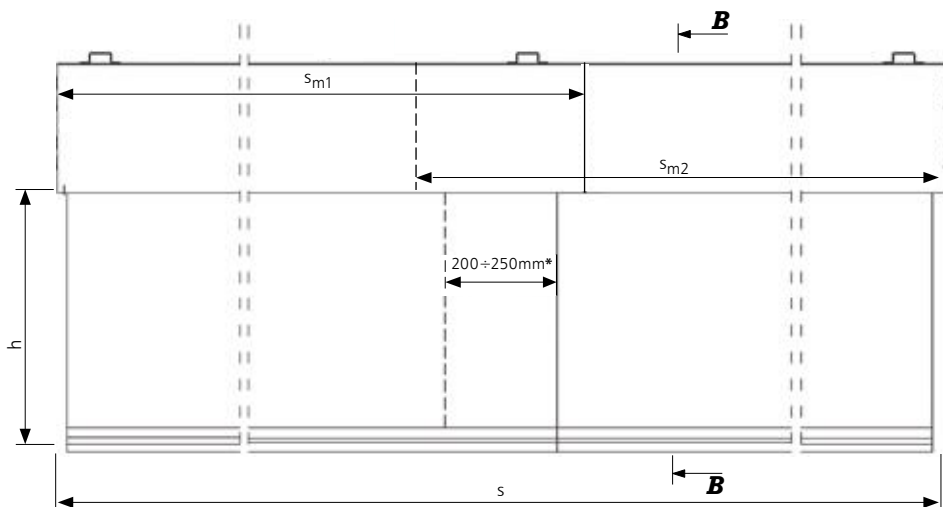

Fig. 52 *mcr PROSMOKE ONE modular automatic smoke curtain in one casing V*

(*) standard overlap

h_1, h_2 – curtain modules height [m]
 s_{m1}, s_{m2} – curtain modules length [m]

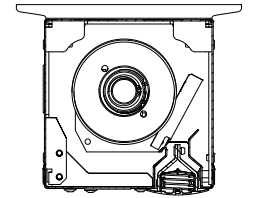

Fig. 49 *Section B-B of mcr PROSMOKE ONE S modular automatic smoke curtain in one casing*

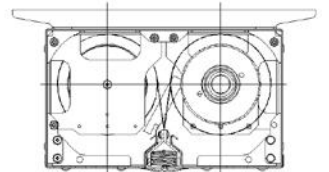

Fig. 51 *Section B-B of mcr PROSMOKE ONE H modular automatic smoke curtain in one casing*

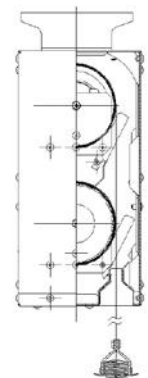

Fig. 53 *Section B-B of mcr PROSMOKE ONE V modular automatic smoke curtain in one casing*

2.5 | **Installation ceiling G-K attached to the curtain**

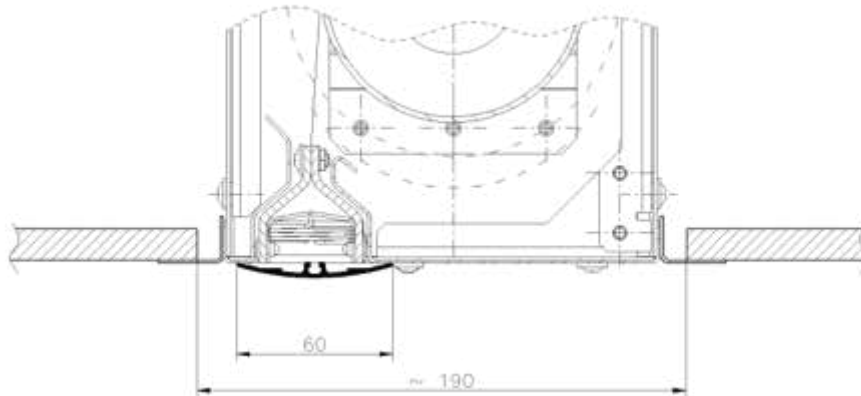

Fig. 54 The guides lateral G-K type 1

» **NOTE:** Only use the masking 60 mm

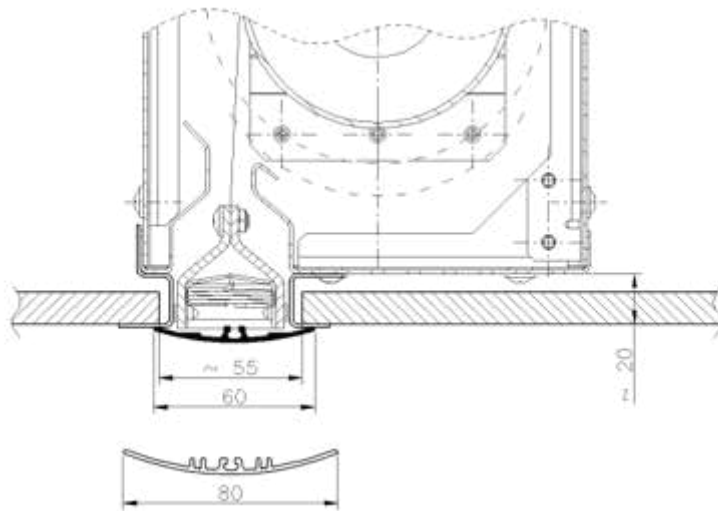

Fig. 55 The guides lateral G-K type 2

» **NOTE:** Use the masking 60 mm or 80 mm

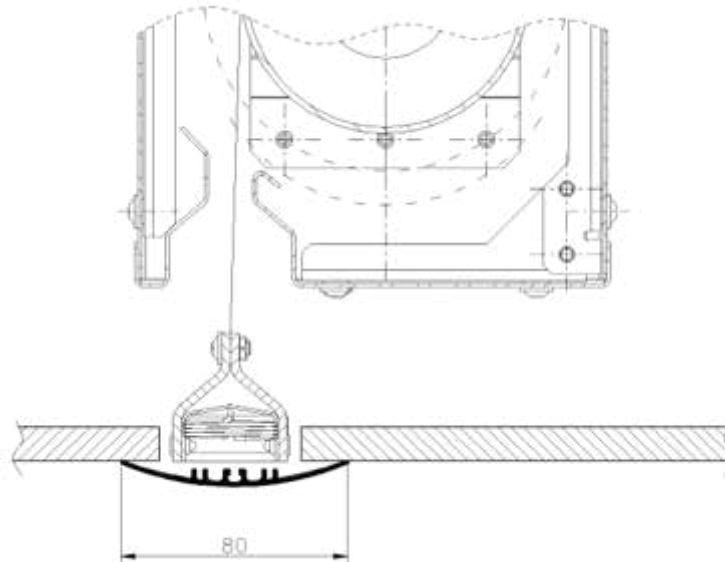

Fig. 56 Without guides G-K

» **NOTE:** Only use the masking 80 mm

3. | Fixed smoke curtains – fabric, mcr PROSMOKE S type

3.1 | Technical description of standard

- » Certification of constancy of performance CE 1396-CPR-0022 as per EN 12101-1,
- » S type fixed smoke curtains serve the purpose of separating smoke zones under the building ceiling, they are mainly used in large-area buildings, such as warehouses, production and sports halls or malls, where the use of light curtains of large size and guaranteed resistance to high temperature is necessary,
- » smoke-tight fabric made of glass fibre double-coated with polyurethane,
- » load bearing element made of galvanized or painted steel sheet in form of angle or flat profiles,
- » pressing profile made of galvanized or painted steel sheet,
- » bottom ballast made of steel elements of maximum length 3 m.

3.2 | Design of fabric-made fixed smoke curtain

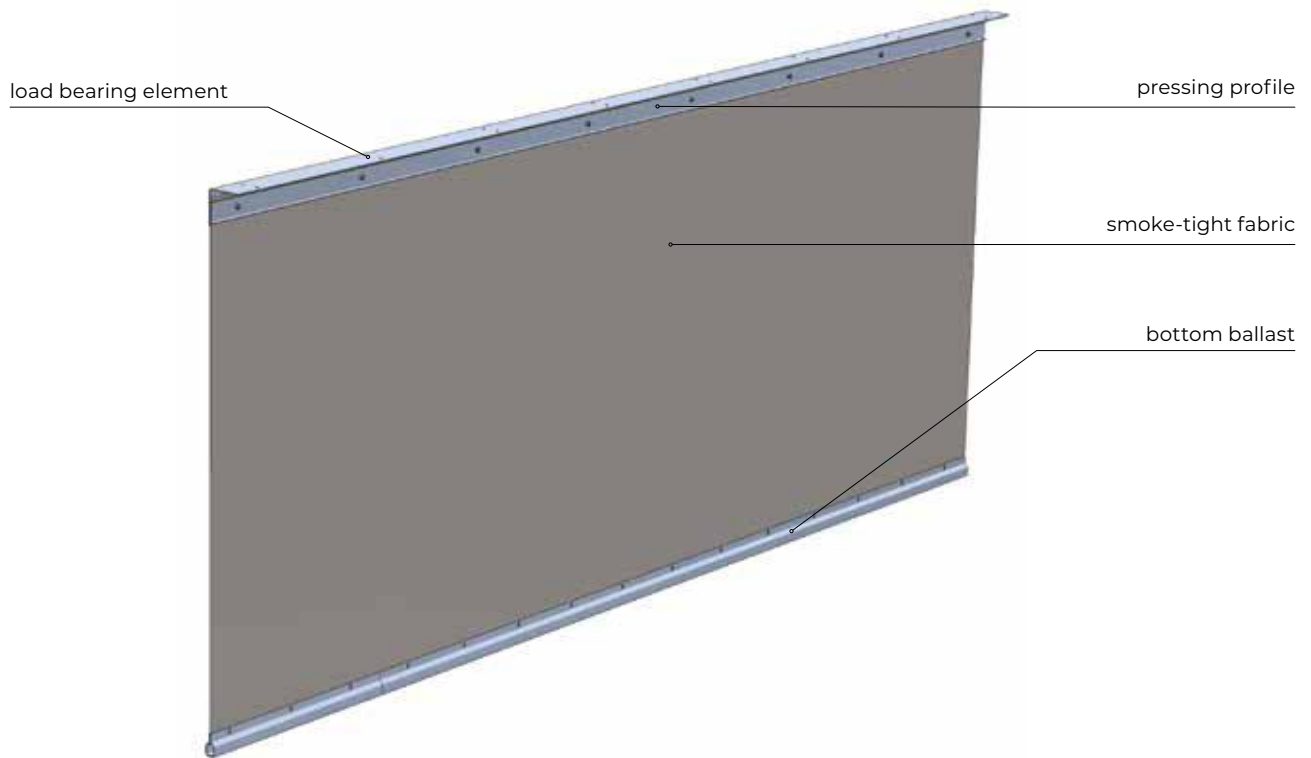

Fig. 57 Design of PROSMOKE S fixed fabric-made smoke curtain

3.3 | Non-standard options

- » steel elements painted to any RAL color.

3.4 | Technical drawings

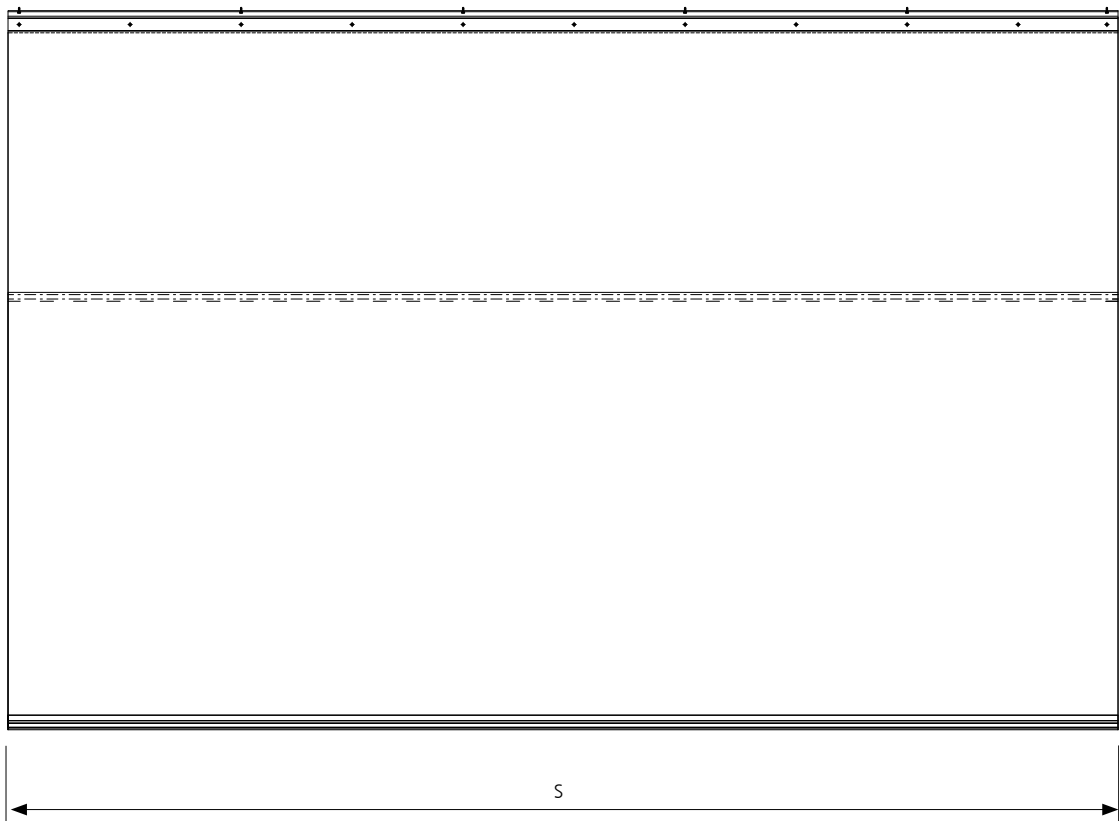

Fig. 58 mcr PROSMOKE S fixed smoke curtain

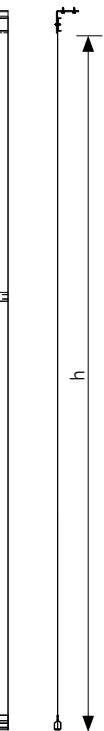

Fig. 59 side view smoke curtain

h – curtain height [m]
s – curtain length [m]

3.5 | Technical details

PARAMETERS	mcr PROSMOKE S CURTAINS
length	50 m
height	min. 0.5 m max. 8.0 m
curtain type	SSB – static smoke barrier
classification	D180, DH60
max. material permeability	$\leq 9,4 \text{ m}^3/\text{h}\cdot\text{m}^2$

3.6 | Installation

- » installation of fixed curtains made of smoke-tight fabric should be made in accordance with the construction design,
- » mcr PROSMOKE S smoke-tight fabric fixed curtains are fixed to permanent elements of the building (lintel, ceiling, wall, beam),
- » curtain may be installed using metal joints (anchors, rods, screws), in intervals on the curtain's load bearing element of 1 m,
- » space between the ceiling and curtain should be covered with a material of A1 non-flammability class (as per EN 13501).

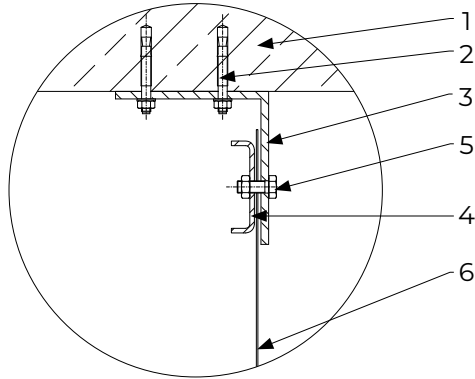

Fig. 60 S type curtain installation under lintel, using angle profile

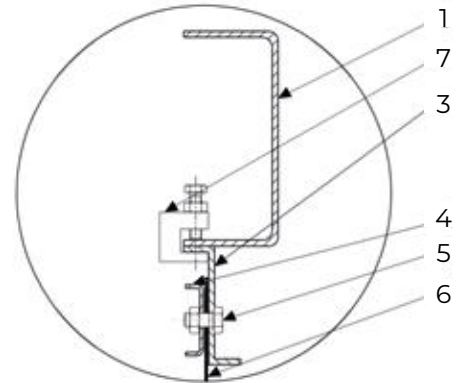

Fig. 61 S type curtain installation to beam with using vices

1. Fixed element of the building / Lintel
2. Connectors for fixing to the fixed elements
3. Load-bearing element (depending on the planned installation method: angle bracket, U-bar etc.)
4. Pressing element
5. Set of connectors (M8 screw, coarse flat washers 2 pcs., secure nut)
6. Smoke-proof fabric
7. Vice

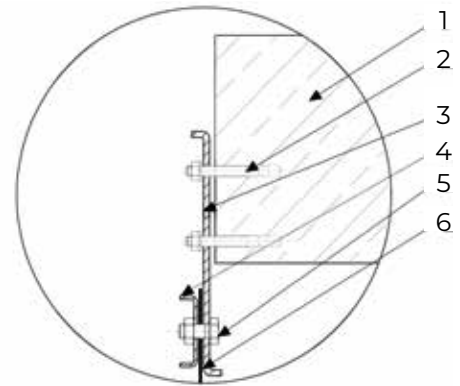

Fig. 62 S type curtain installation to the lintel

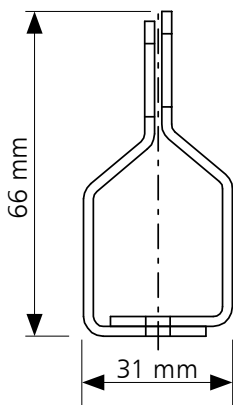

Fig. 63 S type fixed curtain bottom ballast

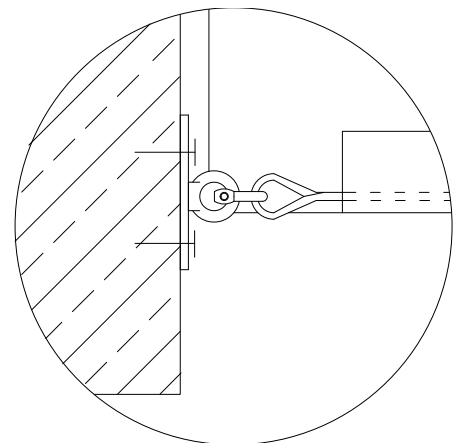

Fig. 64 Fixture of curtain bottom with cable

4. | Fixed smoke curtains – steel, mcr PROSMOKE ST type

4.1 | Technical description of standard

- » Certification of constancy of performance CE 1396-CPR-0037 as per EN 12101-1,
- » mcr PROSMOKE ST fixed smoke curtains are used for separating smoke zones in large hall buildings, mainly production and storage halls, where no limitations to the loading of bearing structure of the building exist,
- » made of TR35 trapezoidal steel sheet of 0.5 mm thickness, zinc coated, Al-Zn or polyester paint,
- » bracing elements in the form of galvanized or painted square pipes,
- » bracing profile in the shape of steel angle profile,
- » covering profile made of galvanized or painted steel sheet,
- » load bearing element of mcr PROSMOKE ST curtain shaped as angle or flat profile made of galvanized or painted steel sheet.

4.2 | Design of steel fixed smoke curtain

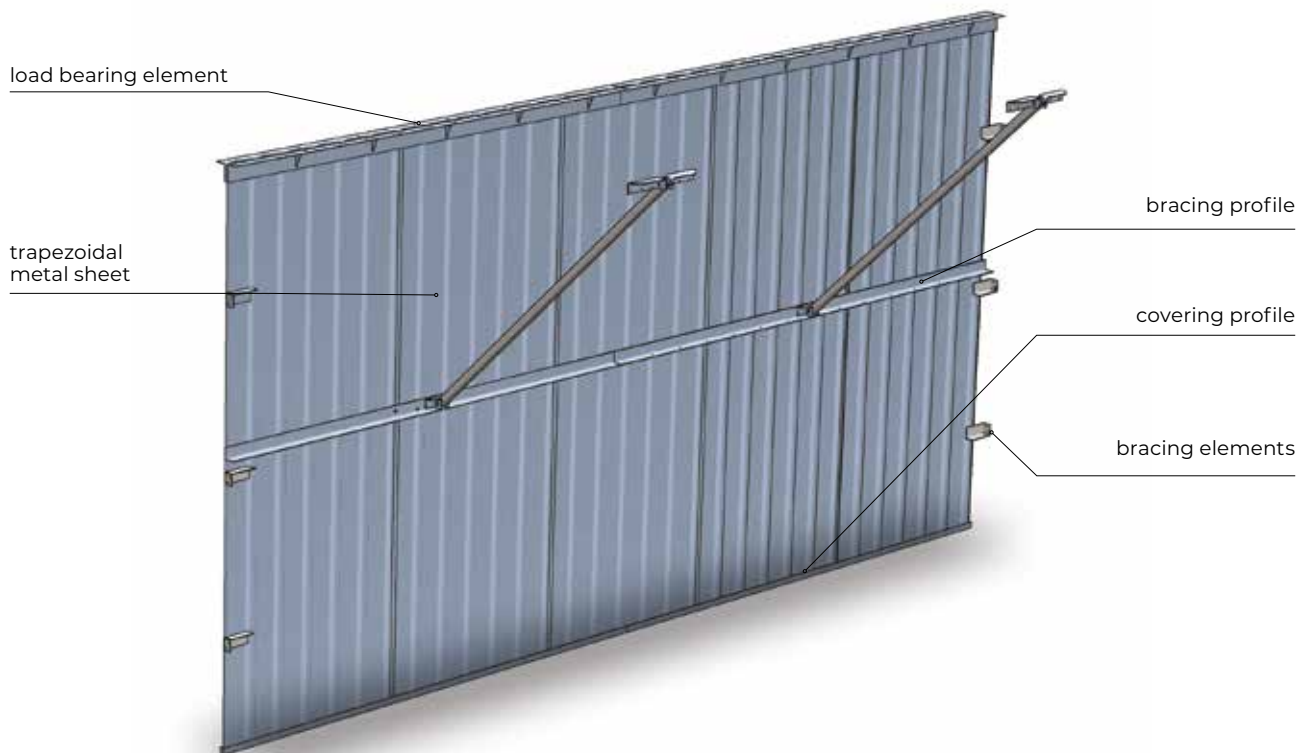

Fig. 65 Design of mcr PROSMOKE ST fixed smoke curtain

4.3 | Non-standard options

- » additional bracing elements used for steel curtains of height ≥ 2.5 m:
 - steel angle along curtain, up to its mid-height,
 - angle profiles made of steel squared pipe, placed every 3 m,
- » metal sheet painted on both sides to any RAL color.

4.4 | Technical drawings

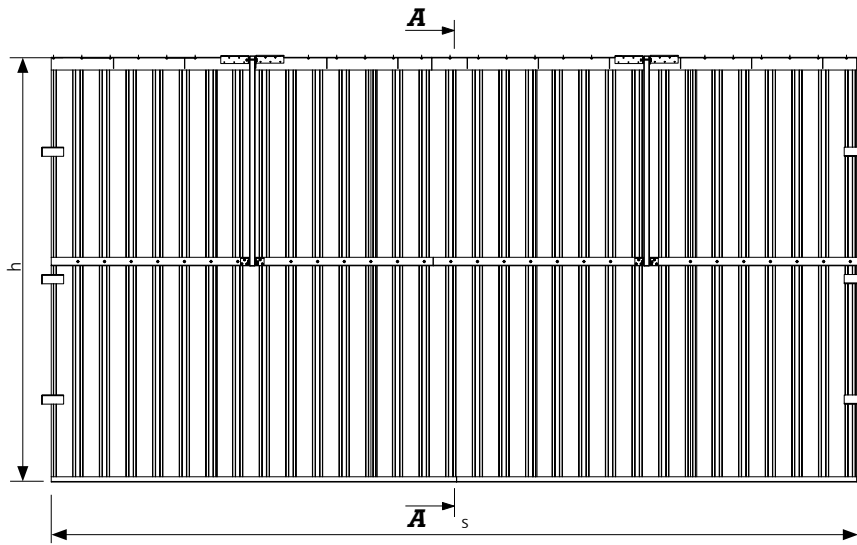

Fig. 66 mcr PROSMOKE ST steel sheet fixed curtain.

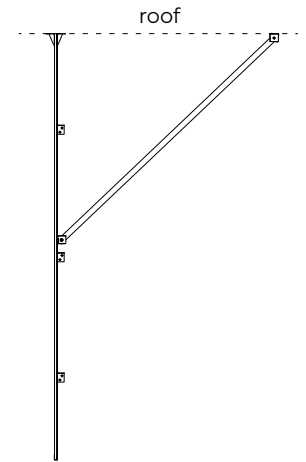

Fig. 67 Section A-A of steel sheet fixed curtain.

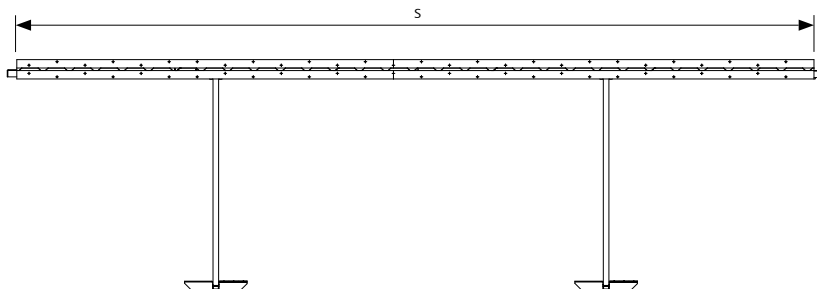

Fig. 68 Top view of mcr PROSMOKE steel sheet fixed curtain

h – curtain height [m]
s – curtain length [m]

4.5 | Technical details

PARAMETERS	mcr PROSMOKE ST CURTAINS
length	unlimited
height	min. 0.5 m max. 4.5 m
curtain type	SSB- static smoke barrier
classification	DH120
curtain sheet weight	4 kg/m ²
standard elements mass	5÷6 kg /1 rm of curtain
bracing elements mass	2÷3 kg /1 rm of curtain

4.6 | Installation

- » fixed smoke curtains made of steel sheet should be installed in accordance with the construction design, and in conformance with EN 12101-1 standard,
- » steel curtains are fixed to structural elements of the building (lintels, beams, girder, etc.) using suitable steel joints.

1. Trapezoidal sheet of the roof
2. Purlin
3. Curtain elements
4. Angle profile
5. Masking element

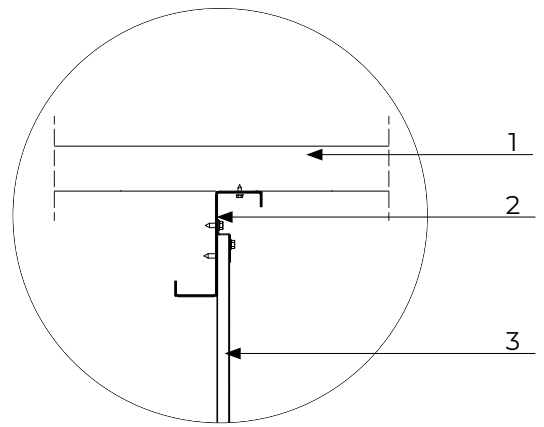

Fig. 69 Sample installation of mcr PROSMOKE ST steel curtain along beam

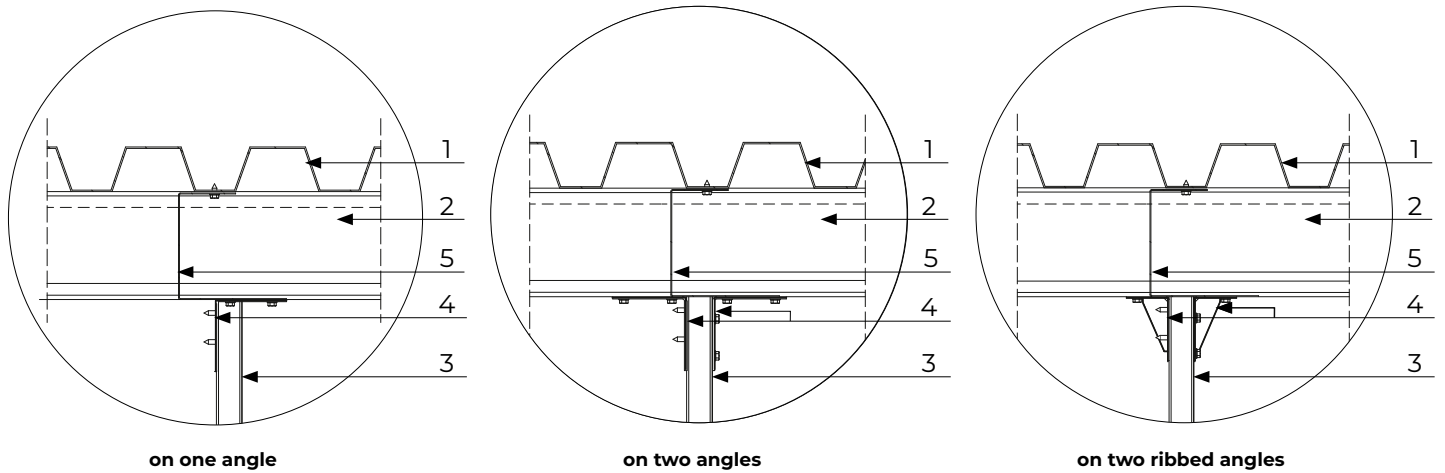

Fig. 70 Sample installation of mcr PROSMOKE ST steel curtain across beam



„MERCOR” S.A.
ul. Grzegorza z Sanoka 2
80-408 Gdańsk, Poland
tel. + 48 58 341 42 45
export@mercortecresa.com.pl

➤ **MERCOR UKRAINE SP. Z O.O.**

Ukraine

www.mercor.com.ua

📍 Scheptyckich 26

📍 79-016 Lviv

☎ +380 32 240 34 47

☎ +380 32 240 34 07

✉ info@mercortecresa.com.ua

➤ **MERCOR FIRE PROTECTION SYSTEMS S.C. S.R.L.**

Romania

www.mercor.ro

📍 Drum Centura Chitila - Mogosoaia, no 3, floor 4

📍 Oras Chitila, Ilfov RO-077045

☎ +40 371 324 182

☎ +40 372 877 070

✉ romania@mercortecresa.com.pl

➤ **MERCOR TECRESA**

Spain

Parque Tecnológico Legatec.

www.mercortecresa.com

📍 C/ Margarita Salas nº 6

📍 28919 Leganés (Madrid)

☎ +34 91 428 22 60

☎ +34 91 428 22 62

✉ info@mercortecresa.com

➤ **MERCOR SLOVAKIA S.R.O.**

Slovakia

www.mercor-slovakia.sk

📍 Galvaniho 7/D

📍 821 04 Bratislava

☎ +421 2 2062 0040

☎ +421 2 2062 0049

✉ mercor@mercortecresa.com.sk

➤ **MERCOR CZECH REPUBLIC S.R.O.**

Czech Republic

www.mercor-czech.cz

📍 Letní 1122/1

📍 721 00 Ostrava-Svinov

☎ +420 597 317 665

✉ mercor@mercortecresa.cz

➤ **MERCOR - DUNAMENTI TŰZVÉDELEM ZRT.**

Hungary

www.dunamenti.hu

📍 Nemeskéri Kiss Miklós utca 39

📍 2131 Göd

☎ +36 30 919-0542

✉ godcenter@dunamenti.hu

➤ **MERCOR FIRE PROTECTION UK LTD**

England

www.mercor-uk.co.uk

📍 Unit P(10), Heywood Distribution Park,

📍 Pilsworth Road, Heywood, OL10 2TT

☎ +44 (0) 0161 3598309

✉ enquiries@mercortecresa.co.uk



European Union
European Regional
Development Fund

